

SEAFLO[®]

ELECTRIC CONVERSION MARINE TOILET

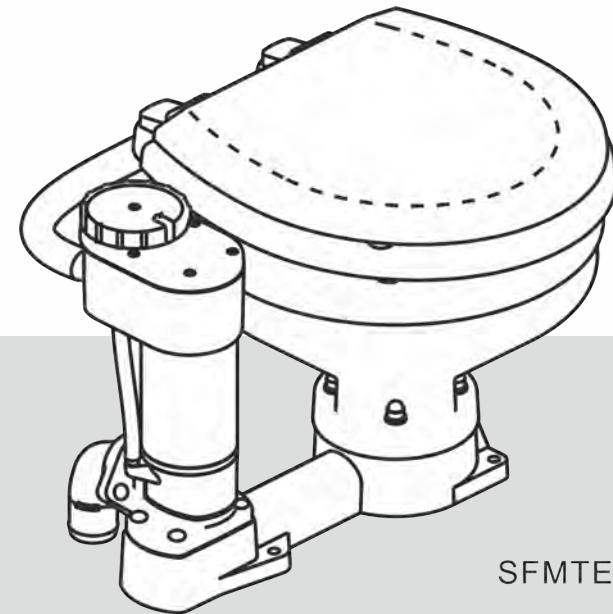

SFMTE-02

The Electric flush pump provides the convenience of an electric head without having to modify the platform or replace the head. The self-priming pump rinses the bowl while the waste pump macerates and evacuates the waste. Add the luxury of an electric head without the costly replacement and hassle by converting your existing toilet with an electric flush kit.

FEATURES

- Both pump & bowl are interchangeable with JABSCO.
- Converts manual head to electric operation
- Simple to operate
- Suitable for use in above or below waterline installations
- Built-in macerator with stainless steel chopper plate
- Left and right-handed installations
- Simple rotary control for 'flush & discharge' or 'discharge only'
- Self-priming pumps permit installation above or below waterline
- Manual pump easy to refit if power supply fails
- Noise - This unit runs with a characteristic 'buzz'

COMPACT SIZE

Electric Conversion Marine Toilet	
Model	SFMTE1-02 SFMTE2-02
Type	Electric
Control Type	Rotary Control
Max Draw	24A at 12V 13A at 24V
Size	Compact
Diameter	3/4" Inlet 1-1/2" Discharge
Material	Ceramic bowl, wood seat with baked enamel finish
Dimension (L*W*H) mm	490 * 445 * 430 (mm) 19.29" * 17.52" * 16.93"

APPLICATION

The SEAFLO electric conversion marine toilet will convert SEAFLO manual toilet to electric operation. It is assembled at the factory to fit the SEAFLO 01-Series toilets. The flush pump assembly simply replaces the entire manual pump assembly and screws directly to the toilet base. In addition to SEAFLO toilets, the flush pump will also fit the Jabsco, Mansfield (Sealand) 751, Raske & Van der Meyde RM69, and Taiwan Magnetics TMC 999 toilet models.

PLUMBING CONNECTIONS

Connect inlet hose using either 5/8" or 3/4" ID hose (a sleeve is included to adapt pump inlet from 5/8" to 3/4"). Make sure all inlet connections are airtight and free of sharp bends or restrictions.

Connect 1" or 1-1/2" hose to discharge port and make suitable connection to holding tank or other discharge system. Avoid sharp bends or restrictions.

For above waterline installations, a check valve may have to be installed in the flush water intake line to ensure rapid pump priming. To retain water in bowl, make a loop in the discharge line about 8 inches above base of bowl.



Flood hazard. Close inlet and outlet seacocks prior to disassembling toilet. Failure to do so can result in flooding which can cause loss of property and life.

Do not connect the toilet to the vessels potable water for its source of supply. To do so can result in contamination of potable water supply. If fresh water is preferred for flushing, provide a separate fresh water tank to supply water to the toilet only.

DO NOT CONNECT INLET HOSE TO A PRESSURIZED WATER SYSTEM.

If the toilet is, or can be, below waterline at any normal (including static) attitude of vessel heel and/or trim, a 3/4" Vented Loop Fitting must be installed in the length of hose connecting the flushing pump to the inlet seacock. The Vented Loop Fitting must be positioned so it remains slightly* above the waterline at all angles of heel and trim.

* Recommended minimum height above waterline is 6".

INSTALLATION

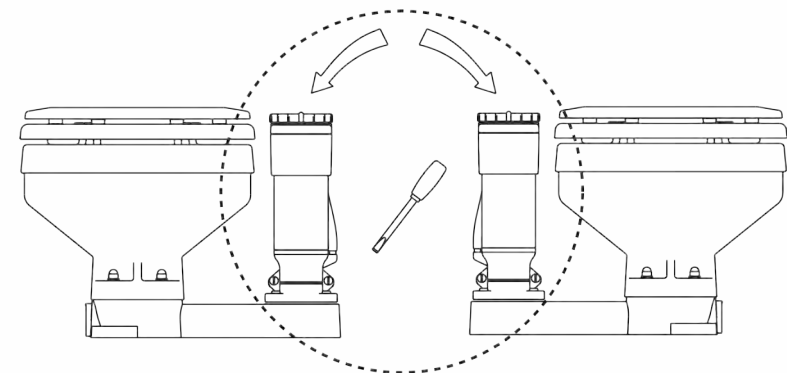

Reversible pump

The SEAFLO electric toilet may be installed above or below the waterline. Flush pump is self-priming with a vertical lift up to 4 feet; discharge macerator pump can operate against a vertical head up to 4 feet.

Inlet and outlet seacocks should be easily accessible and be positive shut off valves. If seacocks cannot be conveniently operated from toilet location, install suitable shut off valves for inlet and discharge connections.

Base assembly may be moved 90° to accommodate connections and provide accessibility for servicing.

Surface where toilet is mounted should be flat to prevent distortion of toilet base.

ELECTRICAL SPECIFICATIONS

RATED VOLTAGE	NOMINAL FUSE		WIRE SIZE PER FEET OF RUN				
	AMPS	SIZE	0'-10'	10'-15'	15'-25'	25'-40'	40'-60'
12	24	25	12	10	8	6	4
24	13	15	16	14	12	10	10

* Length of run is the combined distance from the positive power source to the flush pump and back to ground. Wire sizes recommended will allow no more than a 5% drop in voltage.

OPERATING INSTRUCTIONS

NOTICE: Do not run pump dry for more than ten seconds. To do so may result in damage to the pump impeller.

To flush the toilet simply turn the large flush control knob clockwise to the flush position. In the flush position the flush Pump provides rinse water to the bowl while the waste pump simultaneously macerates and discharges the waste. Hold it in the flush position long enough to evacuate all waste.

To evacuate liquid from the bowl so it will not slosh while underway, turn the flush control knob counterclockwise to the drain position. In the drain position the flush pump will lower the liquid level to the bottom of the china bowl while incoming rinse water is reduced to a minimum.

If the toilet bowl is empty, a small amount of water may be added to the bowl prior to use by turning the flush control knob to the flush position.

The waste pump is designed to handle waste and toilet tissue (either household type tissue or Marine/RV water soluble tissue is acceptable) but it will not handle sanitary napkins, tampons or hard solid objects.

SERVICE INSTRUCTIONS



Flood hazard. Before performing any service, close all waste system seacocks. Failure to do so can result in flooding which can cause loss of property and life.

Disconnect the electrical power to the flush pump.

Detach the discharge elbow, flange and joker valve.

Remove the inlet hose and toilet bowl link hose from the flush pump.

Remove the screws that attach the flush pump to the toilet base and lift the pump assembly from the base.

CONVERTS MANUAL HEAD TO ELECTRIC OPERATION

To change the mounting flange, remove the four screws (on bottom of pump assembly) which secure the mounting flange to the waste pump body. Note the relative position of the long and short screws. Grasp the pump body, wearplate and motor with one hand, holding them together as an assembly. Then slide the mounting flange/macerator housing off the pump body with the other hand trying not to disturb the wearplate and damage the paper gaskets. It may be necessary to gently tap on the flange with a plastic mallet to start it sliding off the pump body.

If the gaskets are damaged, they should be replaced with new ones (provided) before attaching the new mounting flange/macerator housing. To do this insert a blunt rod dowel into the discharge hole in the pump body and push it against the impeller to prevent the motor shaft from turning. Unscrew and remove the chopper from the motor shaft. Lift the wearplate and gaskets from the pump body and clean any paper residue which may stick to the wearplate and body. Reassemble with new gaskets by reversing the procedure.

Before assembling the new mounting flange/macerator housing to the pump body, ensure the discharge port O-Ring is properly positioned in the O-Ring groove of the pump body. Secure the flange to the pump body with the two shorter screws and the pump assembly to the motor with the two longer screws.

Before removing the manual pump, flush the toilet for sufficient time to ensure all waste is thoroughly flushed from the discharge hose.

Remove the 3/4" inlet hose and toilet bowl link hose from the manual pump. Detach the discharge elbow, flange and joker valve assembly from the pump cylinder. It should not be necessary to remove the discharge hose from the elbow.



Flood hazard. Close inlet and outlet seacocks prior to disassembling toilet. Failure to do so can result in flooding which can cause loss of property and life.

Remove the screws which secure the pump assembly to the toilet base and retain them to reattach the electric flush pump. Remove the manual pump assembly and the base flapper valve/gasket assembly with attached brass weight. The pump and flapper valve may be disinfected and stowed away for emergency use should the vessel lose electrical power.

Before assembling the electric flush pump to the toilet base, attach the discharge elbow, flange and joker valve to the flush pump discharge. Position the new pump base gasket (provided) on the toilet base. Align the flush pump mounting flange with the toilet base and secure it with the pump mounting screws.

Attach the 3/4" inlet hose to the inlet port (beneath the upper pump pointing down). Do not connect the pump inlet to a pres-surized water system. Attach the bowl link hose to the flush pump discharge port (rear of upper pump pointing back). If the bowl link hose is not long enough or is kinked, replace it with the length of hose provided with the flush pump kit.

If the toilet is positioned below the waterline or may be below the waterline at any angle of heel or trim, the plumbing must include vented loops positioned above the waterline. To do this, remove the length of hose which connects the flush pump with the bowl. In its place install a length of hose long enough to connect the flush pump to a vented loop fitting positioned a minimum of 8 inches above the waterline. Connect the other side of the vented loop fitting to the bowl inlet elbow.

In below waterline installations with the discharge hose connect-ed to a thru-hull fitting, the hose must rise up and be connected to a vented loop positioned a minimum of 8 inches above the waterline and then continue on to the discharge seacock. The total rise of the discharge hose, however, must not exceed 6 feet of head. If a vented loop fitting in the discharge hose positioned at least 8" above the waterline results in a total discharge head that exceeds 6 feet, the electric flush pump should not be installed.

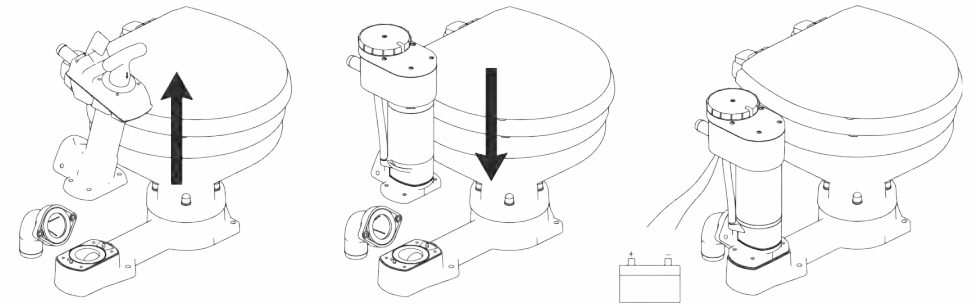
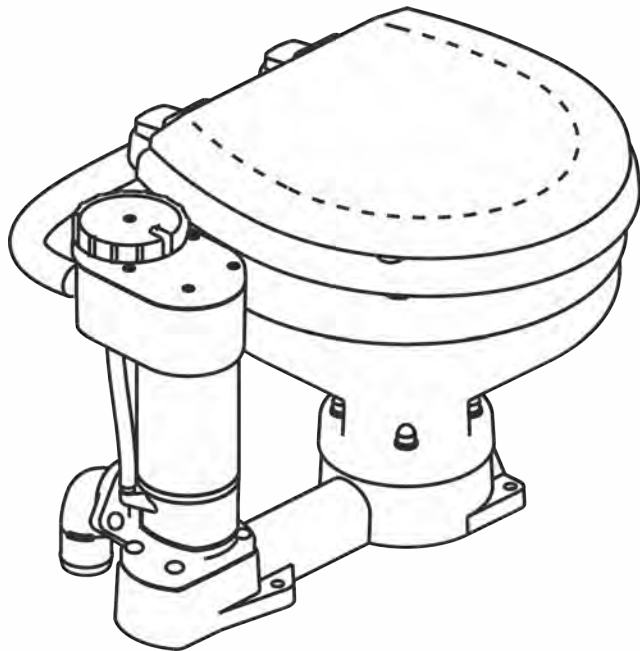

CLEANING



CAUTION: Do NOT use aggressive chemical agents such as Acetone or Bleach because plastic parts may crack and the enamel coating on the seat and lid may blister.

- To clean the bowl, use any liquid or cream ceramic cleaner.
- To clean the rest of the toilet, including the seat and lid, use a non-abrasive liquid cleaner. Polish with a dry cloth only.



CAUTION: Do not use abrasive pads on any part of the toilet and do not use cream cleaners except for the bowl.

- To disinfect the toilet, use a liquid disinfectant diluted in accordance with the manufacturer's instructions. You may apply it to all parts of the toilet using a sponge or soft brush as necessary.



CAUTION: Do not use thick liquid toilet cleansers or neat bleach. They may damage the valves, gaskets, seals and the enamel coating of the seat and lid.

WIRING

The flush pump should be wired to the power source with an electrical circuit independent of all other accessories. The total length of wire should be kept to a minimum and the wire should be sized in accordance with the following electrical specifications chart. The wires, if not run through a conduit, should be supported every 18 inches with non-metallic clamps.

NOTICE: Correct wire size and secure wire connections are very important. Undersized wire and unsecured or corroded wire connections will cause a reduction in pump performance and possible pump failure.

The entire circuit should be protected by an appropriate size circuit breaker or switch panel located as close to the power source as possible.

Connect the red motor lead to positive and the black motor lead to negative. When making connections to the motor leads use only mechanical locking (crimp type) connectors or equivalent and seal the connection with silicone or heat-shrink tube to protect it from corrosion.



NOTE: Do not put anything in the toilet unless you have eaten it first, except toilet paper. Do not put in: Sanitary Towels, Wet Strength Tissues, Cotton Wool, Cigarettes, Matches, Chewing Gum or any solid objects, Petrol, Diesel, Oil, Solvents of any kind or water more than hand hot.

WASTE SYSTEM DISASSEMBLY

1. Remove the flush pump to waste pump bleed tube.
2. Remove the four screws that secure the macerator housing and pump assembly together and to the motor. Note that they are two different lengths with the longer screws securing the pump assembly to the motor.
3. Grasp the waste pump body and motor then pull the base.
4. Remove the O-Ring around the discharge port.
5. Grip the flat of the shaft where it has been exposed by the remove top pump assembly to prevent it from rotating. Unscrew and remove the chopper and its lock washer.
6. Remove the wearplate and two gaskets from the pump assembly.
7. Remove the pump body and impeller from the motor then withdraw the impeller from the body.
8. Through the impeller bore side of the pump housing, push evenly against the shaft seal to press it out of the bore.

WASTE PUMP REASSEMBLY

1. Press the lip seal into the seal bore of the pump body with the open side of the seal facing the impeller bore.
2. Lubricate the impeller bore of the body and the motor shaft with petroleum jelly then slide the pump body onto the shaft.
3. Slide the impeller onto the shaft and with a counter-clock-wise motion push the impeller into the impeller bore.
4. Position a new paper gasket, wearplate and second paper gasket on the shaft against the pump body.
5. Grip the flat of the shaft on the top end of the motor to prevent it from turning. Install the chopper lock washer and the chopper on the bottom shaft.
6. Position the O-Ring in the O-Ring groove around the discharge port.
7. Slide the macerator housing onto the pump body and secure it with the two shorter screws.
8. Position the discharge flange on the same side of the motor where the wire leads enter the case and secure the pump assembly to the motor with the two longer screws.

FLUSH PUMP DISASSEMBLY

1. Remove the control knob screw and the control knob.
2. Remove the seven screws which attach the flush pump cover assembly to the pump body and lift off the cover assembly and the cork gasket.
3. Lift the brass wearplate and the flushing pump impeller out of the impeller bore.
4. Carefully lift the switch from the pump housing taking care not to lose the positioning dowel pin and gently disconnect the red wire leads.
5. Using a blunt punch or small piece of dowel inserted in the inlet port, push upward on the control valve assembly to dislodge it from the flush pump housing.
6. Remove the two screws which secure the flush pump housing to the motor and lift the pump housing off the motor.
7. Through the impeller bore side of the pump housing, push evenly against the shaft seal to press it out of the seal bore.

DIMENSIONAL DRAWING

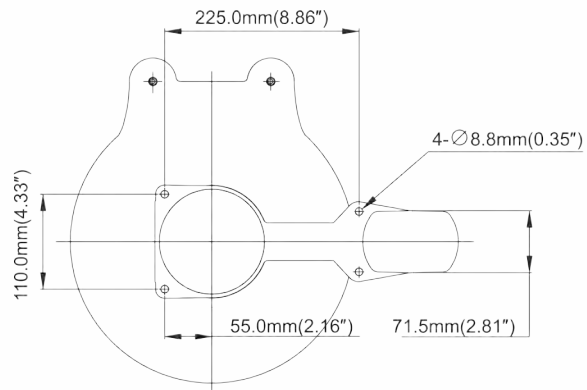

X-X SECTION VIEW
(display base mounting hole)

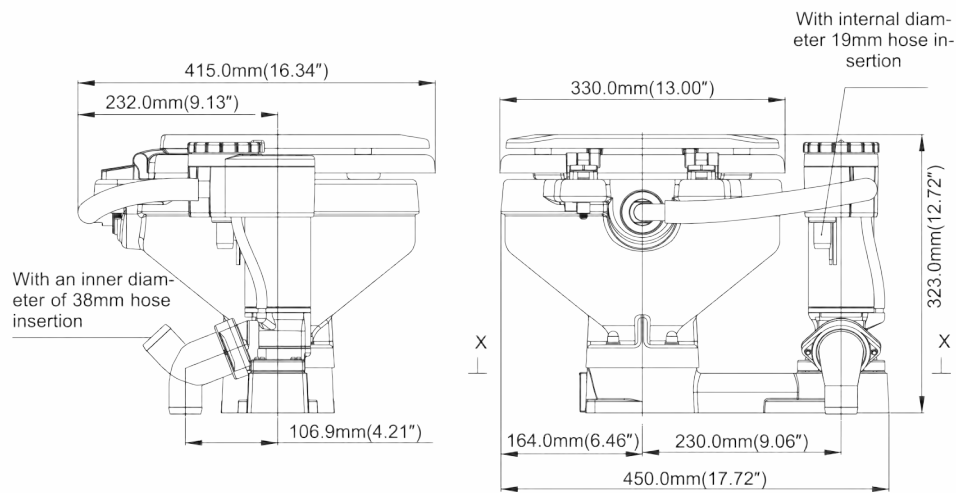

EXPLODED VIEW

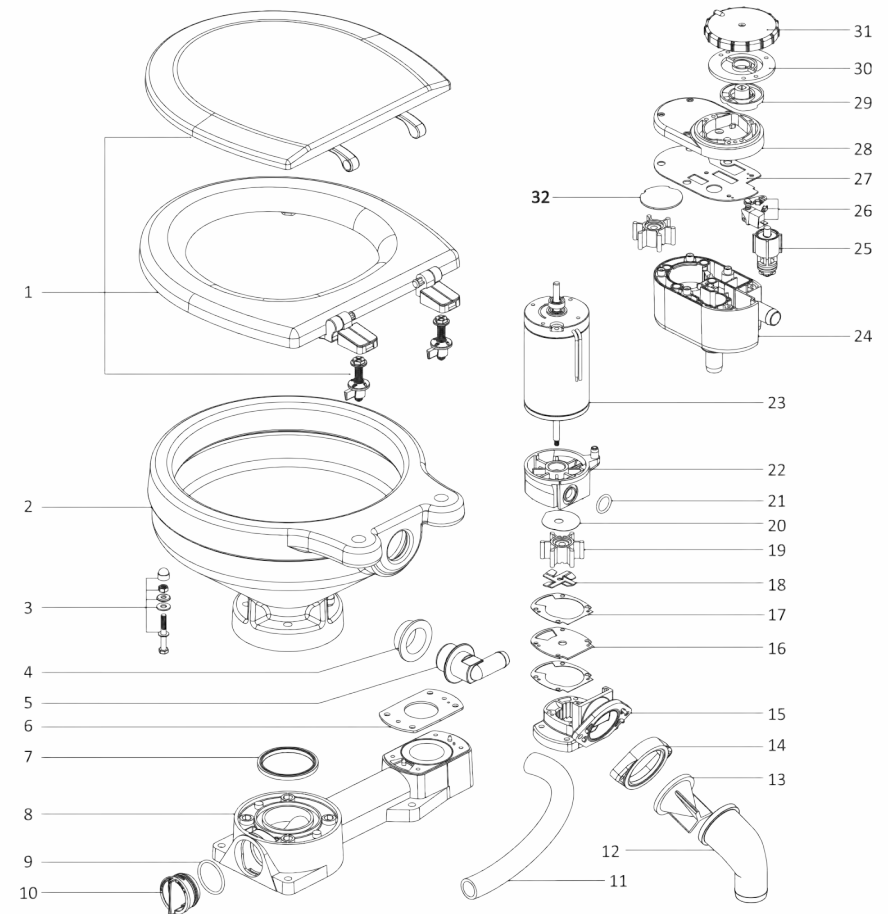

1	Toilet lid assembly	12	Sewage elbow	23	Motor assembly
2	Ceramic bowl	13	Drain valve	24	Middle cover
3	Bolt assembly	14	Flange	25	Check valve body assembly
4	Flush seal	15	Pump head	26	Micro Switch
5	Water inlet elbow	16	Shell compression	27	Middle cover gasket
6	Base seal block	17	Shell seal	28	Upper cover
7	Toilet seal	18	blade	29	Rotating the lower cover
8	Toilet base	19	impeller	30	Fixed cover
9	Plug seal	20	Convex piece	31	Rotating the cover
10	Base plug	21	Seal ring	32	Impeller cover
11	hose	22	shell		